

CYCLE PARKING

Supplementary Planning Document

Adopted 3rd July 2017



WE ARE
WATFORD

watford.gov.uk



Contents Page:

The Importance of Cycle Storage	1
Planning Policy	4
Expected Cycle Parking Provision	6
Fundamentals	14
Benefits of providing secure cycle parking	18
Submitting an Application	19



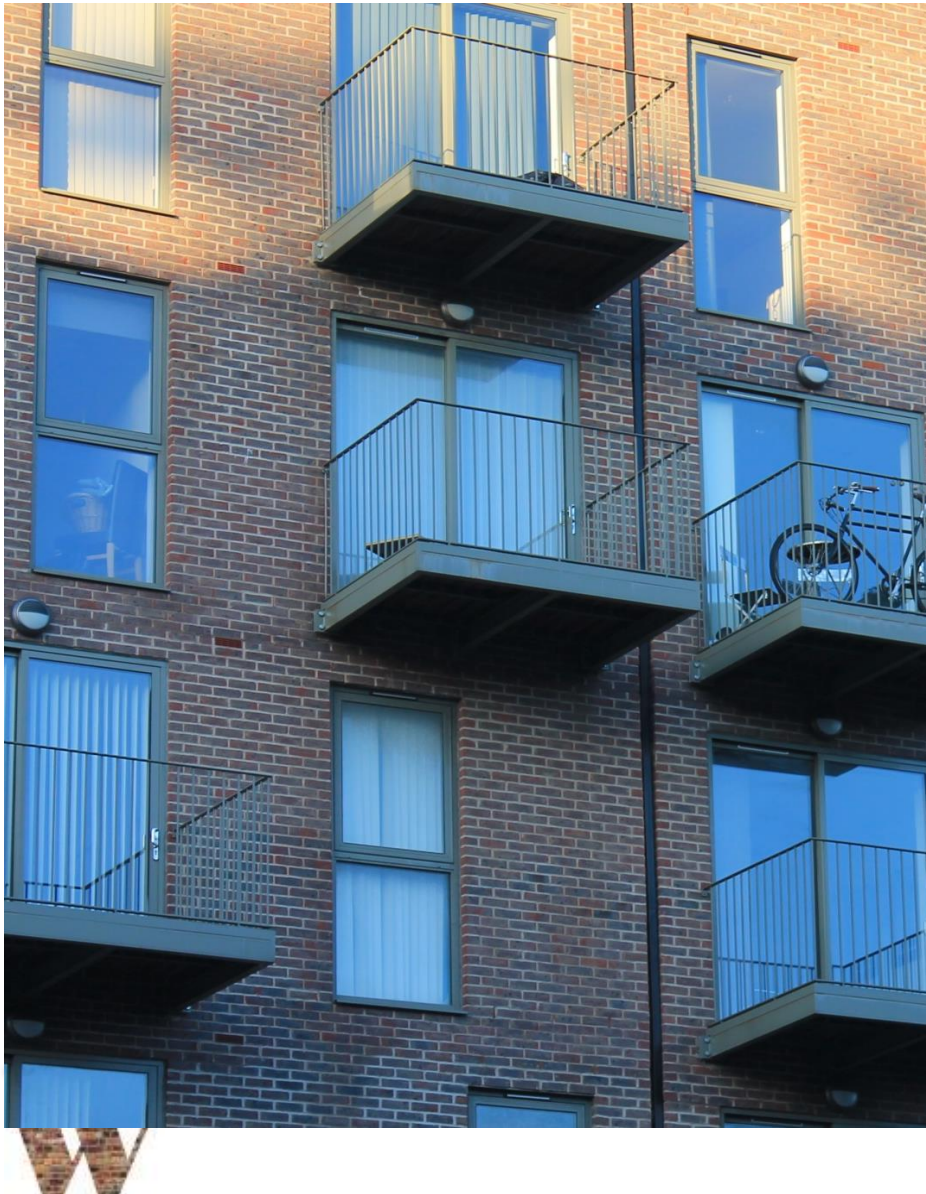

1.0 The Importance of Cycle Storage

The population estimate for Watford on census day 2011 was 90,300. This was an increase of 13.3% compared to the figure of 79,726 from the 2001 Census. Watford's population is expected to reach 100,000 during 2017. Continuing population growth is accompanied with pressure for housing and the associated growth in traffic and congestion.

Watford needs to be smart in the approach to mitigating the impacts of housing growth and potential increase in car traffic. This is not only essential to increase people's quality of life by reducing their commute time but also to ensure that environmental and health impacts from car use are significantly reduced. It is with this in mind that the Council is keen to encourage cycle use in the borough.

Two of the key factors in discouraging cycle use are safety of use when travelling and security of the bike when storing/ parking it.

Bike theft is common in England, despite growing awareness. Data indicates that over 300,000 bicycles are stolen each year in the UK with estimates also indicating that a significant number of people do not resume cycling if their bike is stolen. It is also considered that there are large amounts of under reporting.

There are three points in the cyclist's journey that requires safety and security:

1. Secure storage at the point of origin,
2. Safe cycling infrastructure for the journey
3. Secure storage/parking at the point of destination



The lack of secure cycle storage both at point of origin and destination is one of the key barriers to encouraging cycle use

A UCL Study in 2012¹ identified that most cycle thefts occur in the immediate vicinity of the victim's home such as gardens, sheds

and garages. This is mainly due to lack of secure storage at such locations. At the same time, it is essential to provide adequate cycle parking at the destination point e.g. a person's employment, point of leisure etc.

Cycle parking is an essential part of a development proposal and must be designed into the scheme from the outset. It should not be an afterthought and it is usually **not** appropriate to leave it to be addressed by means of condition after the application has been granted permission, except in small schemes such as conversions.

Cycle parking is also important from a design and maintenance point of view. The lack of appropriate locations for cycle storage risks damage to the fabric of building including stairwells and public spaces which harms the landscape quality of a development and the general perception of an area.

All cycle parking should be designed and located with respect to the historic environment. Taking into consideration ground surfaces, colour and materials.

This Supplementary Planning Document (SPD) is intended to aid designers in setting out site development parameters and should be studied by architects, designers and applicants in advance of submitting a planning application for determination. This



guidance supplements policies T3 (Improving Accessibility), T4 (Transport Assessments) and UD1 (Delivering High Quality Design) of the Watford Local Plan Core Strategy, and T10 (Cycle Parking Standards) of the Watford District Plan 2000. This SPD should be read alongside the latest cycle parking standards.



2.0 Planning Policy

National Planning Policy Framework 2012

Paragraph 29 of the NPPF 2012 recognises the importance of transport policies in facilitating sustainable development. Paragraph 30 states that encouragement should be given to solutions which support reductions in greenhouse gas emissions, and therefore planning authorities in local plans should support a pattern of development which facilitates the use of sustainable modes of transport. Paragraph 35 complements this further by stating that development should be located and designed to give priority to pedestrian and cycle movements.

Watford Local Plan Part 1: Core Strategy

Watford's Core Strategy policies seek to follow up on the requirements of the NPPF 2012. Policy T3 of the Core Strategy applies the following modal hierarchy for assessing development proposals: i) Walking ii) Cycling iii) Public Transport iv). Cars and other road based vehicles. Policy T4 requires transport assessments of proposals – such assessment should include consideration of provision to encourage cycling. Policy UD1 sets out the importance of high quality design.



Solutions to cycle storage should not be an afterthought and should be designed into the scheme from the outset, not dealt with by condition



Watford District Plan 2000

Saved policy T10 expects all new developments to make suitable provision for cyclists.

Accordingly, accessibility for cyclists in new developments is given high priority. This SPD seeks to provide further guidance on how this will be achieved in new developments in Watford. Regard should also be had to other relevant Local Plan policies.



Natural surveillance is essential for all commercial, retail and public place cycle parking provision.



3.0 Expected cycle parking provision

The guidance is divided according to particular uses. In this case:

1. Residential
2. Employment and Educational
3. Retail, Leisure and Community Uses
4. Transport Hubs

The following identifies the principles for cycle storage/parking in each use case. Section 4.0 sets out **expected fundamentals** and some basic required dimensions and should be read in line with this section.

3.1 Residential

For residential developments the following principles should be followed:

- Parking provision should be within the curtilage of the dwelling
- Larger flat development should have individual large item storage
- Access routes between the highway and the cycle storage should be well lit

- Clear connection to the road or cycle paths should be clearly designed
- Have smart/fob type secure access for residents only
- Corridors and access aisle need to be of appropriately wide (see Section 4.0)
- Storage area should be securely segregated from the rest of the basement/ undercroft area, ground floor area not part of the general basement area





Large apartment complexes should have individual secure large cycle storage, while for residential blocks beneath 15 units securely accessed communal storage is sufficient.

Cycle space, storage and parking should be designed from the outset of a project/scheme. Communal cycle storage areas in large flat/apartment type development where large numbers of people have access to the storage area are not sufficient security.

Developments over 15 units

For developments over 15 units, it is expected that there will be a storage cage assigned to each individual dwelling. This storage should be large enough to accommodate cycles (see section 4.0), as well as other household and leisure items, e.g. prams, fishing equipment, surf boards.

This area should be located on the ground or basement floors but it must have fob/safe access from the remainder of the basement area i.e. any car parking or visitor cycle area. Ideally there should be a stair-free level ramped access to this area from the entrance and with suitably wide corridors and access points to allow easy movement of cycles to and from the public highway. This type of individual storage is likely to be provided in schemes which are 'car lite' developments, close to public transport and therefore should not cause cost/space conflicts with car parking provision.

For secure storage for blocks of flats the entrance door should be BS PAS 24: 2016 or equivalent.

Developments under 15 units

For apartment developments, or converted buildings with fewer than 15 units, a secure accessed communal area with individual racks should be provided. Similarly this should be fob only access



for the residents of the block and be separate from any other space on the ground or basement floors e.g. bin stores or car parking. Within this communal area either stands or slide and rack systems that can take a D lock need to be provided.

Access to communal areas need to be easy, where basement parking is provided below ground level appropriate ramp solutions need to be integrated into the design.

Source: Cambridge City Council



Source: Cambridge City Council

If stairs are walkable, wheeling ramps should be as shallow as possible.

Conversions

The council recognises the difficulty of providing cycle storage for re-development of an existing building, for example conversion of a large house into separate flats. These schemes will be assessed on a case by case basis.

Dwelling Houses

For dwellings houses, storage in private garden sheds or garages are sufficient with the use of a shed shackle where possible

Visitors Parking for residential blocks

Visitor parking can be provided outside the residential block and individual Sheffield stands are sufficient for this aspect of the development.

Key questions:

Is the parking area within the footprint of building?	✓
Is individual large item storage provided for large apartment schemes	✓
For houses is there adequate private garage space?	✓
Are minimum corridor width requirements provided?	✓
Is there sufficient internal manoeuvrability?	✓
Are there good connections to public highway	✓



Is there secure, resident-only access to the cycle store?

Electric-assisted cycles are becoming increasingly popular and have the potential to open up cycling to a much wider population for utility journeys in particular. Consideration should be given to providing electric cycle charging equipment within secure communal cycle storage in residential development (apartment buildings) for residents' use. Cycle parking provision should also include a proportion of parking facilities which can accommodate 'non-standard' cycles – such as cargo bikes, tricycles, adapted cycles, tandems and bikes with child trailers or trailer bikes

3.2 **Employment and Education**

For employment and educational developments the following principles should be followed:

- Parking should be located as close as possible to the main entrance
- Parking facilities provided within the footprint or the building or at the very least securely locked covered communal stores.
- Constantly under natural and electronic surveillance

- Racks/stands designed to facilitate the use of D type locks
- Easily found and well-advertised
- Changing facilities for employees provided
- Covered facilities for employment and recreational uses
- Clearly designed connections to road or cycle paths
- Storage areas and access routes to them should be well lit



Employment and educational uses should have covered and secure communal storage. Access is normally employee only key/fob

Places of employment and education are the end points for commuting and therefore a higher level of security is required as opposed to other non-residential development. A working day is



regularly over 7 hours and on street; standard Sheffield/ M stands cycle racks with no covers or secure access are **not** suitable.

For educational and employment based activities

- The storage/parking should be secure, covered, with employee only access.
- This should be located within the footprint of the building for large office and employment buildings.
- A For smaller offices and units a securely accessed covered store close to the entrance of the building is sufficient.

The storage/parking should be in well-lit areas with good natural surveillance. The storage hubs/facilities should avoid being overly garish or institutional in appearance.

Are there sufficient and access arrangements to the cycle area?	✓
Are there good connections to the public highway?	✓

Electric-assisted cycles are becoming increasingly popular and have the potential to open up cycling to a much wider population for utility journeys in particular. Large employers should be encouraged to provide electric cycle charging equipment within secure communal cycle storage. Cycle parking provision should also include a proportion of parking facilities which can accommodate ‘non-standard’ cycles – such as cargo bikes, tricycles, adapted cycles, tandems and bikes with child trailers or trailer bikes

Key questions:

Is the storage near the main entrance?	✓
Is the storage area safely locked and covered?	✓
Are there changing facilities for the user on site?	✓
Is there employee only secure access?	✓
Is there sufficient natural surveillance?	✓



3.3 Retail, leisure and community uses

For retail, leisure and community uses the following principles should be followed:

- Parking should be located as close as possible to the main entrance
- Constantly under natural and electronic surveillance
- Need to facilitate the use of D type locks
- Easily found and well-sign posted



For retail and other short term visits, standards racks or stands near the entrance of the building or facility should be provided. Covered protection from the elements is preferable.

Retail and other uses that require short term visits, e.g. those under two hours, should provide appropriate racking/ stand facilities. Standard bike stands with good natural surveillance located near entrances are sufficient. The provision of some

covered racks would be preferable for larger premises. Such stands should be capable of double locking with D locks and be in line with the key dimensions in Section 4.0.

Longer term secure parking will also be need for employees in line with the requirements in Section 3.2.

An adequate number of stands need to be provided and this should be in line with the latest parking standards for each use.

Cycle parking provision should also include a proportion of parking facilities which can accommodate ‘non-standard’ cycles – such as cargo bikes, tricycles, adapted cycles, tandems and bikes with child trailers or trailer bikes

Key questions:

Is the storage near the main entrance	✓
Are the stands of sufficient size and capable of double locking?	✓
Is there good natural surveillance?	✓
Are there good connections to public Highway	✓
Is there CCTV coverage to deter theft?	



3.4 Transport Hubs

A transport hub is a structured site/place where passengers exchange between various modes of transport. i.e. places such as Watford Junction and stations along the Abbey Line and the Metropolitan Line.

For Transport Hubs, the following principles should be applied:

- A mix of a secure locked compound or a covered area where these can be provided
- Very visible, easy to find stands/racks and near the main entrance
- Should ideally have facilities to suit different preferences
- Clear connection to road or cycle paths

Transport hubs can involve both long term and short term parking requirements. However, they are often used as part of a commute to work, when combined with a bus or a train journey. They may also be considered for park and ride facilities

Although transport hubs are generally long visits with regard to cycle parking, the sheer volume of passengers and patrons of transport networks means that secure individual or securely accessed communal stores are unviable. Small scale cycle lockers

may be individually provided, however it is clear that the amount of cycle parking required is significant with demand continuing to grow.



Covered double racking cycle facilities near the station entrance or inside the station are the preferred parking facility for public transport interchanges but they should not affect passenger movement or the appearance of the station.

Concurrently, single standard stands may not be efficient utilisation of space. Double racking allows for more spaces to be provided and this will help improve cycle parking capacity at train stations.

Cycle parking provision should also include a proportion of parking facilities which can accommodate 'non-standard' cycles –



such as cargo bikes, tricycles, adapted cycles, tandems and bikes with child trailers or trailer bikes.

Furthermore, the stands and racks need to be covered from the elements, either internally as part of the station or as part of dedicated facilities outside but near the station entrance. This is essential.

These areas need to be well lit and located in places with good natural surveillance. CCTV and other security measures are essential here, and similarly to other uses, the bike racks/ stands need to be able to take doubling locking with D locks.

Bicycle storage at transport hubs should be provided for free and with low barriers to entry e.g. not having to request access to a bike store or purchase a key.

Key questions:

Are the cycle facilities covered/ weather proofed?	✓
Is the area overlooked or near access points to the station?	✓
Is there good natural surveillance?	✓
Are there clear connections to public highway?	✓



4.0 Fundamentals

General Considerations

All new cycle parking should be designed and located with respect to the historic environment and should take account of existing ground surfaces, colours and materials. In addition, consideration should be given to ensuring that new cycle stands which are likely to obstruct routes used by the public can be distinguished from the surrounding floor or boundary surfaces through the use of contrasting colours and textures.

4.1 Basic Dimensions for cycle storage

There are a number of fundamentals regarding dimensions of a bicycle and the movement of cycles that need to be taken into account when designing cycle parking into a new development scheme.

The dimensions of a conventional bike when designing communal, individual cycle storage or street cycle storage should be appraised with due regard to the following:

1. The cycle store itself
2. Access to the store
3. Connecting to the wider network

For parking and access, it is important to note that the width of an average adult bike is **650mm** with a length of **1800mm**. However this width increases to **1100mm** (as a minimum) for a cyclist pushing a bike as illustrated opposite.

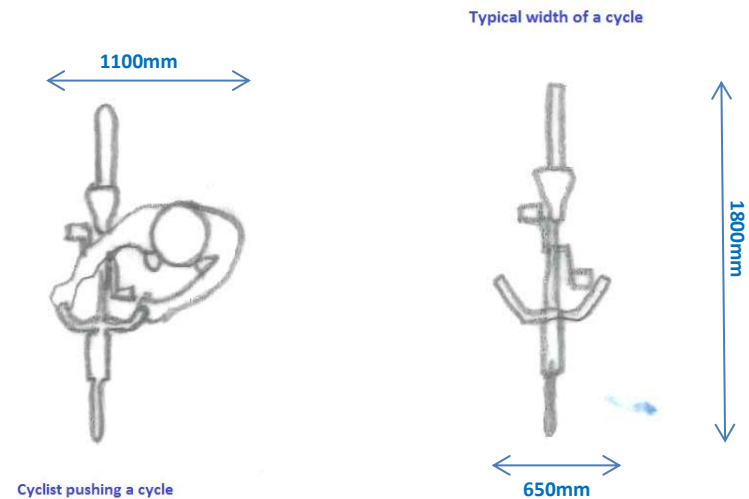

Figure 1: Key Cycle Dimensions

Where individual large item storage is provided, this should enable adequate space for cycles and large items. This should be a minimum of **1400mm x 2000mm**, with a minimum **1100mm**



access door. Aisle access needs to be similar to conventional corridor width (1100mm) and should allow for turning and manoeuvring. This follows the principle illustrated in Figure 1.

Larger storage will be encouraged to accommodate larger units where required for family-sized flats.

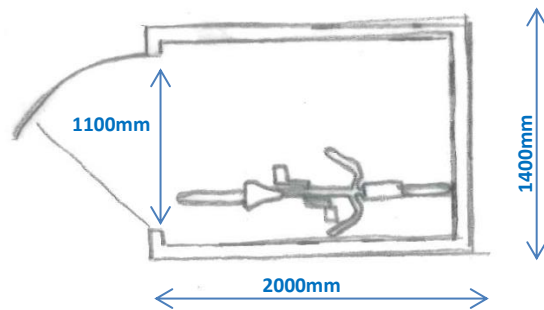

Figure 2: Dimensions for individual large item storage.

Where communal storage is provided, the size of the communal area will relate to the number of units or the amount of floorspace for non-residential uses. The number of spaces should correspond with the latest cycle parking standards

Aisle widths should be **1100mm** for access to these areas. This also needs to be considered for double tier racking facilities or

vertical facilities. It should be noted that a standard bike footprint should be taken as **2000mm x 1000mm**. This allows for some space between the stands for manoeuvring (as illustrated opposite). Storage facilities should also provide some spaces that will accommodate non-standard cycles. (as stated in Section 3.4).

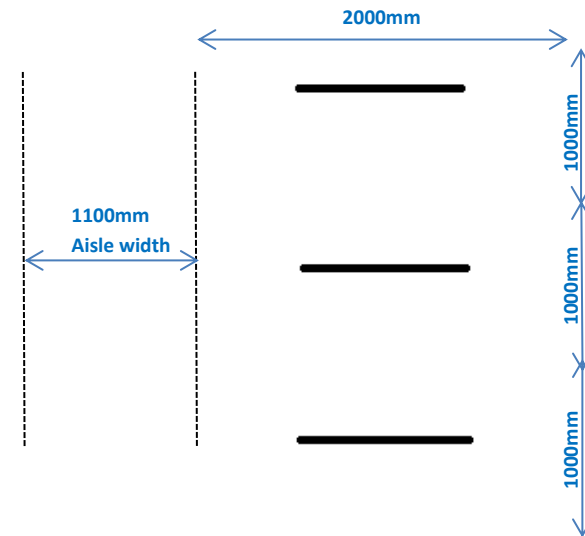

Figure 3: Dimensions for communal stands provision

Although it is preferable to avoid consecutive door access to an internal cycle area, this may happen on occasion. Access and



consecutive door corridors need to be designed with turning in mind. A good design will allow for turning internally by ensuring that consecutive doors have sufficient space between them for a person pushing a bike to manoeuvre.

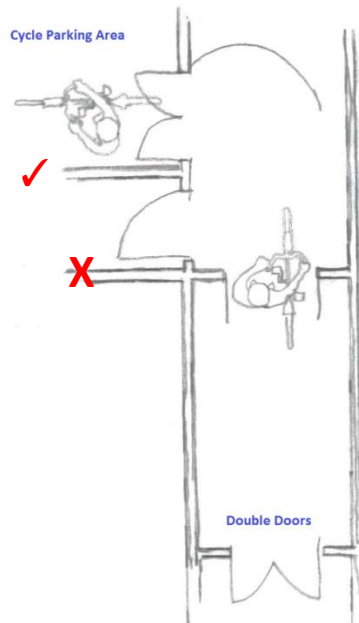

Figure 4 – internal Access Arrangements

In addition, it is important to ensure that cycle storage or stands should not be placed on a sloping gradient and natural surveillance is key. Cycle stand dimensions as described should be capable of taking double locking D Locks.



A typical stand should measure 750mm x 750mm with spacing of 1000mm between the standards



Cycling is growing and the demand for secure cycle storage is increasing – bikes are getting increasingly expensive and insurance companies can require basic locking requirements. Secure cycle storage needs to be provided in all new developments



5.0 Benefits of providing secure cycle parking in new development

- Sufficient, convenient, secure and attractive cycle parking at the start and end of a journey is necessary for people to choose to cycle that journey. The potential benefits of increased cycling cannot be realised without it.
- Desirability of cycle parking in new developments in urban areas is increasing
- Reduced air quality impacts/ pollution impact due to less car trips generated
- Lower cost and land take of cycle parking provision compared to car parking.
- Road safety and traffic congestion reduction which can be accounted for in any transport assessment
- General health benefits



6.0 Submitting an Application

Applications for new developments will need to accord with the relevant Local Plan policies including T3 and UD1 of the Local Plan Core Strategy and the latest cycle parking standards (currently in Appendix 2 of the Watford District Plan 2000 but under review). Applicants will need to demonstrate:

- How cycle parking has been incorporated into the design. This can be included in a Design and Access Statement.
- Details by way of drawings regarding the location and number of cycle spaces to be provided as part of a development
- Details of security/ access arrangements for the storage area
- How cycle parking provision has been including in any transport assessment required by Policy T4 of the Core Strategy.

ⁱ Sidebottom, A. (2012). *Bicycle (bike) theft*. JDiBrief Series. London: UCL Jill Dando Institute of Security and Crime Science. ISSN: 2050-4853.



watford.gov.uk



WATFORD
BOROUGH
COUNCIL